

Mid-West[®] Instrument

Model 106 DPI "Micro-switch" Installation and Operating Instructions



INSPECTION

Before installation carefully check the Model Number on each instrument against the receiving paperwork and the intended application. Inspect for shipping damage and, if damaged, report it immediately. Verify when the unit is unpacked and in a vertical position that the pointer is on zero. **If the pointer is off zero see TROUBLE SHOOTING for instructions on zeroing the pointer.**

NOTE: **BEFORE ATTEMPTING REPAIRS,**
CONTACT YOUR LOCAL MID-WEST
REPRESENTATIVE OR OUR FACTORY.
FAILURE TO DO SO WILL VOID ANY
WARRANTY.



CAUTION:

Rapid pressurization can cause severe damage to the sensing element. Rapid pressure change (either increase or decrease) is a change in pressure occurring fast enough to drive the instrument full scale in one (1) second or less. See installation portion of this I.O.M. for guidance in how to prevent rapid pressurization.

PRODUCT DESCRIPTION

The Model 106 are all-metal differential pressure gauges capable of operating at low differential pressures for up to 6000 PSI of line pressure (Material configuration dependent).

The standard unit is equipped with one or two independently adjustable SPDT switches which can be set on decreasing or on increasing pressure. A switch adjust screw and a switch lock screw is accessible after removal of the lens and bezel (removal of 4 screws). The enclosure is weatherproof to the CSA Type 4 classification.

Interface to the snap acting micro-switch is via color coded 18 AWG flying leads and a 1/2" FNPT conduit connection. The assembly does not need power to operate.

The DPIS is also equipped with a Bi-directional Over Pressure Relief Valve (OPV). When the Differential Pressure exceeds 130% of the range the OPV equalizes the pressure between the Hi and Lo sides. Dual top and bottom connections are provided as standard. The DPIS is also equipped with a pointer zero "micro-adjust". If necessary the pointer can be re-zeroed.

INSTALLATION

All Mid-West "DPIS" alarm-controls are calibrated and tested prior to shipment and are ready for immediate installation. Use of the following installation procedures should eliminate potential damage and provide optimum trouble free operation.

- 1. CONNECTIONS** – Unit is equipped with dual ¼" FNPT connections top & bottom. Be sure that one "high" and one "low pressure connection is plumbed to the proper connection on your system. The remaining two ports should either be plugged or plumbed as bleeds. Facing the front of the gauge, the "High" port is on the right.

NOTE: It is strongly recommended that a 3-valve manifold be used in plumbing your model 106 to your system. Properly used it should insure that your instrument is not over-ranged or damaged by pressure shocks during pressurization. It will facilitate later zeroing, ranging and calibration checking. It is good practice to purge or flush the instrument loop prior to connecting the instrument.

When pressurizing the instrument have the bypass valve open. Slowly open the high side and low side isolation valves. When the unit is pressurized close the bypass valve to obtain a DP reading.

When removing the instrument open the bypass valve prior to closing the high side and low side isolation valves. Leave the bypass valve open when venting the instrument.

- 2. ELECTRICAL** – Unit is supplied with a ½" FNPT conduit hub located at the bottom of the unit. An appropriate connector must be installed before making connections to the 18" color coded flying wire leads. Wire functionality is defined as follows with zero differential pressure applied to the instrument. For 2 switch units, the left switch will be identified as the low switch and the right switch will be identified as the high switch. The color coded leads will be marked 1 (for low) and 2 (for high).

Single Switch		
Color	Function	Label
White	Common	1-Com
Black	Normally Closed	1-NC
Red	Normally Open	1-NO
Green	Earth Ground	

Double Switch			
Set	Color	Function	Label
Low (Left)	White	Common	1-Com
	Black	Normally Closed	1-NC
	Red	Normally Open	1-NO
High (Right)	White	Common	2-Com
	Black	Normally Closed	2-NC
	Red	Normally Open	2-NO
	Green	Earth Ground	

CAUTION: Follow all local Electrical Code requirements.

NOTE: Install the front cover and bezel assembly after adjusting the switch and do not leave the unit outdoors without a connector in the electrical opening or the unit may be damaged from environmental conditions.

SETPOINT ADJUSTMENT For single switch units, the switch is adjustable for decreasing differential pressures from 90% to 3% of the full scale range of the gauge and on increasing pressure from 15% to 95% of the Full Scale range. (Unless otherwise specified the decal is located for decreasing pressure set points) For 2 switch units the set point adjustment span on increasing pressure is 20% - 95%. For decreasing pressure the set point adjustment span remains the same. The adjustment screw, the set point lock screw, the switch set feedback(if provided), and the switch set flag (optional) are located inside the enclosure to protect against unauthorized adjustment. Before opening the unit to make a set point adjustment, check plant operating procedures and electrical codes. For access, remove the (4) bezel screws and the bezel assembly.

Note: For a flow dial the flow reading must be converted to differential pressure for set point verification. Set point feedback decal is not provided for gauges with a flow dial.

Setpoint Adjustment (Bezel and lens removed)

Switch Set: Decreasing Pressure: (Skip steps 1 & 2 for units that are not provided with a set point feedback decal)

1. Unlock the switch set by turning lock screw approximately ½ turn CCW. Adjust the set point adjust screw CW until the set point feedback is well below the desired switch point. Slowly turn switch adjust screw CCW until the Switch feedback is near the desired switch point.

2. With an appropriate pressure source and switch continuity checker / meter, apply pressure to the unit and verify the switch set point. If a more precise set is required perform sequence 3.
3. Apply pressure to the unit until the desired set point pressure is reached. If there is no continuity between the white and red wires, slowly reduce the set point of the switch (Turn CW) until there is continuity between the White and Red wires. If there is continuity between the white and red wires, slowly increase the set point (adjust CCW) until there is no continuity between the White and Red wires.
4. Tighten the lock mechanism (Rotate CW). Verify the switch set.
5. If ordered with a switch flag, loosen switch flag screw and manually adjust to actual switch setting. Retighten flag screw.

Note: In most cases the lock mechanism will increase the switch point 1-2% as the lock is engaged. For a more accurate set, set reduce your set pressure by 1-2% of the FSR when setting the switch.

Switch Set: Increasing Pressure: (Skip steps 1 & 2 for units that are not provided with a set point feedback decal)

1. Unlock the switch set by turning lock screw approximately ½ turn CCW. Adjust the set point adjust screw CW until the set point feedback is well above the desired switch point. Slowly turn switch adjust screw CCW until the Switch feedback is near the desired switch point.
2. With an appropriate pressure source and switch continuity checker / meter, apply pressure to the unit and verify the switch set point. If a more precise set is required perform sequence 3.
3. Apply pressure to the unit until the desired set point pressure is reached. If there is continuity between the white and red wires, increase the set point of the switch (Turn CCW) until there is no continuity between the White and Red wires. If there was no continuity between the white and red wires, slowly decrease the set point (adjust CW) until there is continuity between the White and Red wires.
4. Tighten the lock mechanism (Rotate CW). Verify the switch set.
5. If ordered with a switch flag, loosen switch flag screw and manually adjust to actual switch setting. Retighten flag screw.
6. Replace the bezel assembly and screws.

Note: In most cases the lock mechanism will increase the switch point 1-2% as the lock is engaged. For a more accurate set, set reduce your

set pressure by 1-2% of the FSR when setting the switch.

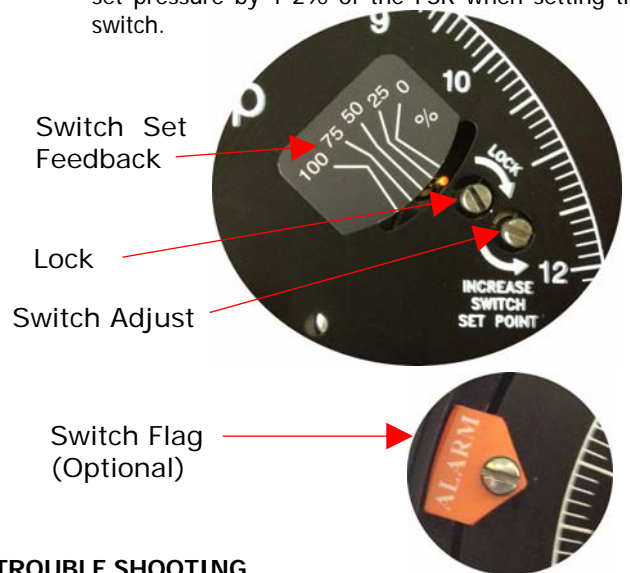

TROUBLE SHOOTING

1. Gauge does not indicate differential.

- A. Check for proper hook up, high to high and low to low.
- B. Make certain that block valves are open and, if using a 3-valve manifold, that the equalizer (balance) valve is closed.
- C. If A and B check out correctly, loosen or disconnect the high pressure line to determine if there is pressure to the instrument.
- D. If there is pressure to the instrument, check to determine that there is a differential across the unit being monitored. If there is, contact the factory for assistance and for an "RGA" (returned goods authorization) number to return the instrument for repair or replacement.

2. Indicating pointer off zero. (With block valves closed, equalizer valve open, or no system differential.)

- A. Tap gauge **lightly**.
- B. Make certain block valves are closed and equalizer valve is open.
- C. If A & B do not correct the "off zero" condition, remove the bezel and lens assembly by removing the (4) bezel screws. Grasp the pointer hub between the thumb and forefinger. Using a straight blade screw driver adjust the screw on the pointer clockwise to adjust the pointer upscale or counter clockwise to adjust the pointer downscale. Tap the gauge lightly to confirm the pointer is on zero. Reinstall the bezel and lens assembly.

RECALIBRATION AND/OR REPAIR

1. If recalibration or repair is required, secure an "RGA" (returned goods authorization) number from Mid-West Instrument and return the instrument to the factory.
2. If (1) is not practical, we recommend you discuss your problem with one of our customer service representatives and request a "technical service" manual. Please have both the model and serial numbers available before calling.

Specification

ELECTRICAL



® Industrial Control Equipment

Input Voltage: None required

Set Pointers:	Quantity:	1 or 2	
	Adjust:	3% to 90 % of Full Scale	Set on Decreasing
		15% to 95% of Full Scale (Single Sw)	Set on Increasing
		20% to 95% of Full Scale (Double Sw)	Set on Increasing

Output(s):	Contact(s):	1 or 2 SPDT	
	Contact Rating:	4 Amps Maximum	@ 30 VDC
		3 Amps maximum	@ 240 VAC
		5 Amps	@ 120 VAC

Temperature: Operating: -20F to +185 F

Environment: Standard: Weather-proof Housing CSA TYPE 4

Electrical Interface: Standard: 18" ., 18 Awg., 600V, 105 C, ½" FNPT color coded wire leads

Gauge Accuracy:* (Decreasing Pressure) 2% For all Single Switch Including effects of the switch, Double switch for ranges 200" H2O and above.

4% Double Switch units including effects of the switch. For ranges 80" – 199" H2O only.

Switch Repeatability:* 2% Max. for all single switch units & all double switch units ranges 200" H2O and above.

4% Double Switch units for ranges 80" – 199" H2O only.

* Accuracies and repeatability values for 2 switch units are based upon one switch set low (approx 25% FSR & one switch set High approx. 75% FSR.).

MECHANICAL:

Material: Body; Aluminum, Carbon Steel, Stainless Steel, or Brass (See IM 105-106/xx Part Numbering System)
Moving Parts: 316/L SS
Bezel, Housing: Anodized Al

Ports: ¼" FNPT Top & Bottom

Working Pressure: 6000 PSI (Material dependent) See IM 105-106/xx Part Numbering System
Proof Pressure: 2X working pressure or 10,000 PSI whichever is lower at ambient temperature

Dial: Black Aluminum with White Lettering

Pointer: White Aluminum, micro adjust

Environmental: CSA Type 4

Standards: C22.1 No.14-10 ; C22.2 No 94-M91 Type 4 enclosure

MANUFACTURER RESERVES THE RIGHT TO CHANGE SPECIFICATIONS WITHOUT PRIOR NOTICE

FIGURE 2: DIMENSIONAL DATA

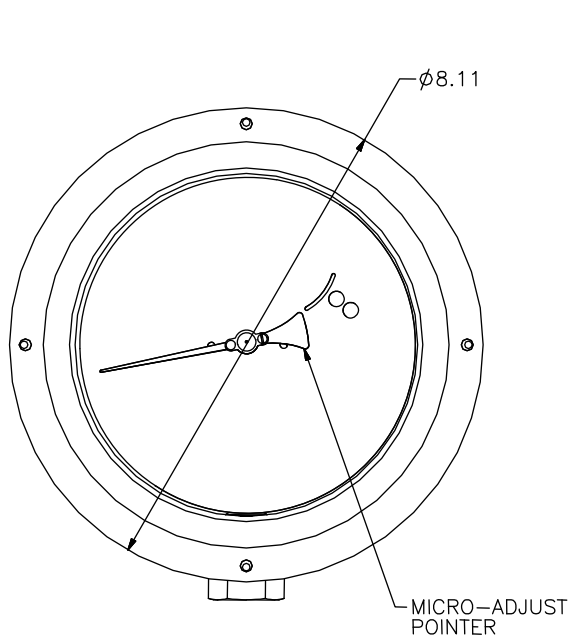

WEATHERPROOF

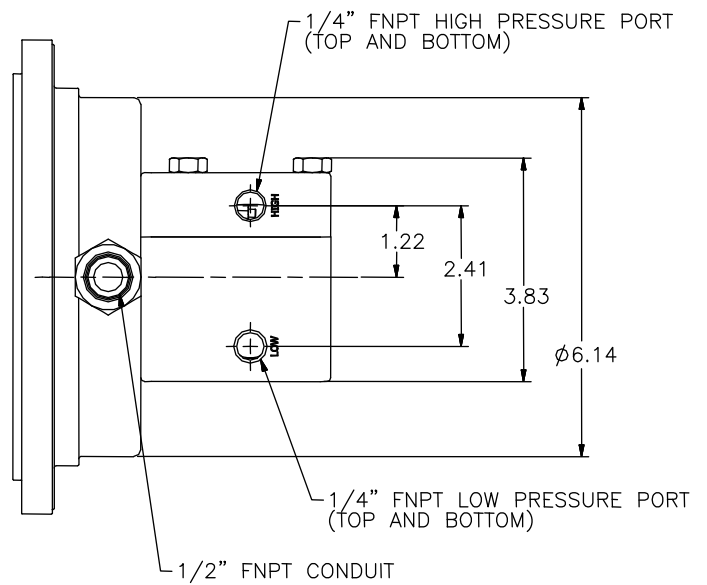
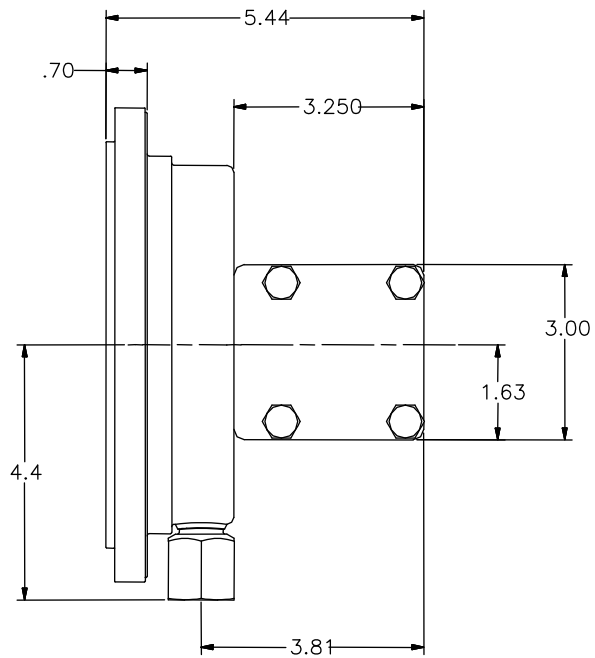

Mid-West®

Instrument

6500 Dobry Dr. Sterling Heights, MI 48314

(586)254-6500 FAX (586)254-6509

E-Mail: sales@midwestinstrument.com

Web Page: www.midwestinstrument.com