

Installation and Operating Instructions - Model 109 Series

1. Safety



Before installing verify compatibility to the process media and temperature in contact with the wetted parts. Incompatible media and / or operation at temperature extremes can cause premature degradation of materials which could result in safety risk to personnel.

Verify the selected pressure range (differential pressure and working pressure) are within specification for your application.

Warning! Remaining media may result in a risk to personnel, environment etc. Use sufficient precautionary measures when removing and transporting the product.

1.1 Intended use: The differential pressure gauges are used for monitoring differential pressures in industrial applications. The manufacturer shall not be liable for any claims if the product is used in applications contrary to the intended use.

1.2 Personnel: Personnel installing and putting this instrumentation into service shall be suitably trained and qualified in accordance with local codes, practices and regulations.

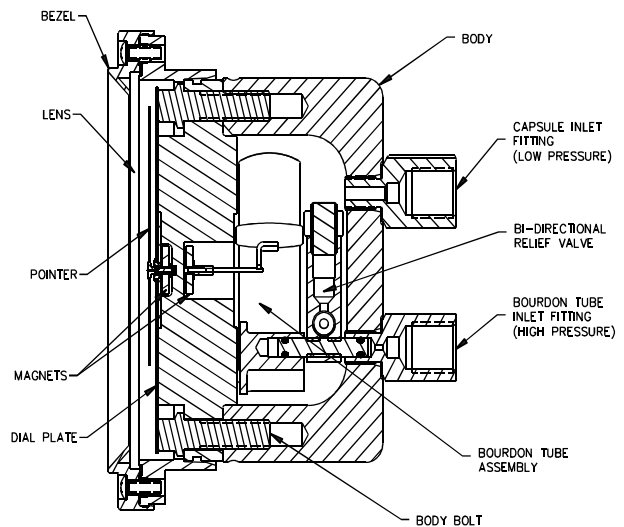

PRODUCT DESCRIPTION

The Model 109 is a precision differential pressure gauge capable of working in systems requiring medium to high differential pressure readout. A test quality bourdon tube assembly is used to sense the differential pressure. The assembly is encapsulated in a high pressure chamber that is fitted with a pressure connection to the inside of the bourdon tube and a second connection to the pressure chamber.

The output shaft of the bourdon tube and gauge movement is magnetically coupled through the solid wall of the pressure chamber to a sensitive jeweled pointer shaft in the dial housing outside the chamber. The bourdon tube is protected against over-range, in either direction, to the rated working pressure by a bi-directional relief valve.

MODEL 109

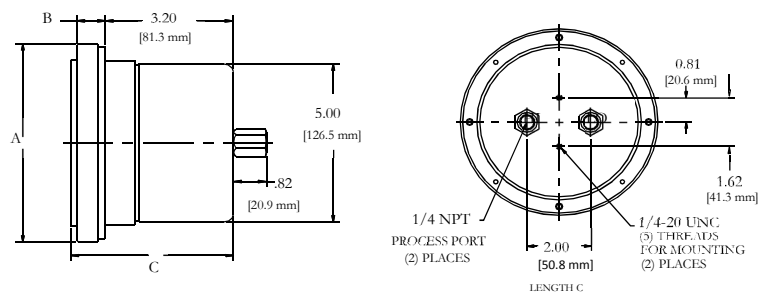

DIAL SIZE	DIAMETER A Inch (mm)	LENGTH B Inch (mm)	LENGTH C Inch (mm)
4 1/2 in.	6.21 (157.7)	.70 (17.6)	4.05 (102.9)
6 in.	8.18 (208.0)	0.76 (19.3)	4.11 (104.4)

Installation and Operating Instructions - Model 109 Series

INSPECTION

Before installation check the nameplate on each instrument against the receiving paperwork and the intended application for correct part number, materials of construction, working pressure, dial range, etc. If equipped with switches, check electrical rating, type of enclosure, etc. Inspect for shipping damage and, if damaged, report it immediately.

NOTE - Before attempting repairs contact your local Mid-West Representative or our factory. Failure to do so will void any warranty.

INSTALLATION

1. CONNECTIONS

(2) 1/4" FNPT pressure connections (fittings) are provided on the back of the gauge body as standard, but check paperwork for connections ordered. They are identified as "HIGH" and "LOW" for high pressure and low pressure. Be sure that the high gets connected to the high and the low to the low side of your system.

2. INSTRUMENT LOCATION

On liquid service the instrument should be located **below** the process connections to facilitate self-bleeding and on gas service it should be located **above** the process connections to promote self-draining. If the process contains particulates, "pigtail" loops or drop legs (manometer "U-tube" configuration) in the tubing will minimize the possibility of the particulates migrating into the instrument.

NOTE: ON LIQUID APPLICATIONS, UNEQUAL LIQUID HEADS ON THE HIGH OR LOW SIDE WILL RESULT IN AN INACCURATE DIFFERENTIAL PRESSURE INDICATION.

3. INSTRUMENT INSTALLATION RECOMMENDATIONS

Model 109 is calibrated and tested prior to shipment and is ready for immediate installation. Use of the following installation procedures should eliminate potential damage and provide optimum trouble-free operation.

Rapid pressurization can cause severe damage to the sensing element in pressure instruments. Rapid pressure change (either increase or decrease) can be described as a change in pressure occurring fast enough to drive an instrument full scale in less than one second.

Most better quality instruments have over-range protection built-in but they are mechanical in design and cannot be relied upon to react in time to protect the instrument against a rapid change in pressure.

The simplest method to avoid this problem is by installation and proper use of a 3-valve manifold. Open the equalizer valve prior to opening one or both of the block valves to insure pressure is applied simultaneously to both sides of the sensing element.

If a 3-valve manifold is not used, protection can be provided by installation of Mid-West Model 150 snubbers to both sides of the instrument. This unit provides an infinitely adjustable choke valve and an excess flow ball check. The ball check is designed not to shut off completely but will restrict flow during sudden changes in pressure while bleeding pressure to the instrument, preventing sudden surges from being transmitted to the instrument.

Refer any questions regarding these recommended procedures to the local Mid-West representative in your area or our factory in Sterling Heights, Michigan, U.S.A.

4. PANEL MOUNTING

The Model 109 is designed for mounting through the **front** of the instrument panel and is normally provided with a panel mounting kit. The kit consists of (4) panel mounting studs and nuts.

Make the cutouts as indicated in (Fig. 1). Insert the (4) panel mounting studs, finger tight, into the metal inserts located in the rear of the bezel.

Insert the gauge through the panel, aligning the panel mounting studs with the holes in the panel. Install the #8-32 nuts onto the studs and tighten securely.

MODEL 109 PANEL CUT-OUT

DIAL SIZE	PANEL CUTOUT A		BOLT CIRCLE C	
	Inch	(mm)	Inch	(mm)
4 1/2 in.	5.30	(134.6)	5.63	(143.0)
6 in.	6.50	(165.1)	7.00	(177.8)

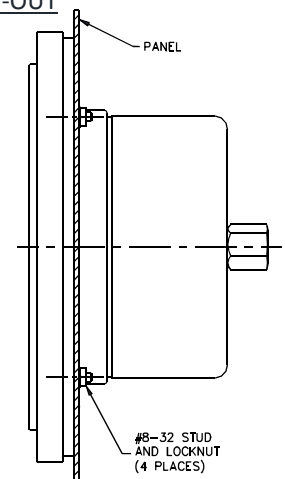
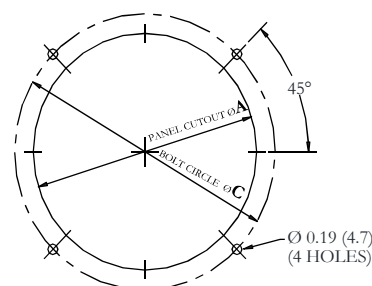

Installation and Operating Instructions - Model 109 Series

5. PIPE MOUNTING

If specified, your Model 109 will have a pipe mounting kit installed. This provides for mounting on a 2" vertical or horizontal pipe. See below for details.

2 INCH PIPE MOUNT (FOR VERTICAL OR HORIZONTAL PIPE)

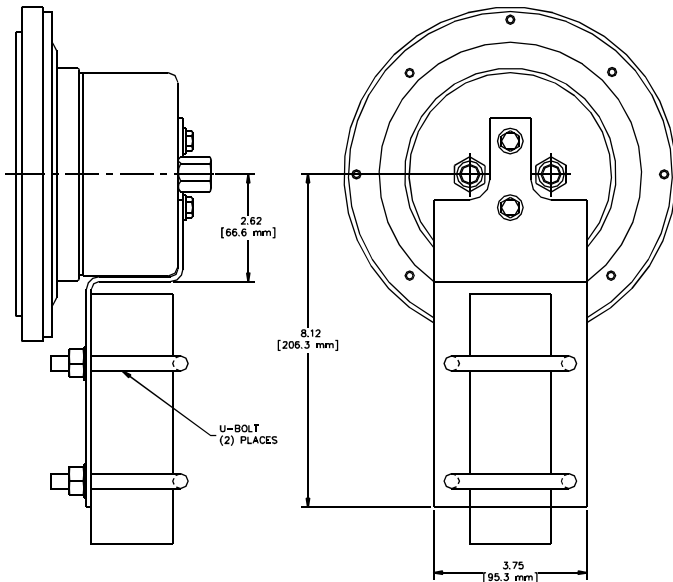

6. WALL MOUNTING

If specified, your Model 109 will have a wall mounting kit installed. This provides for mounting on a panel or wall. See below for details.

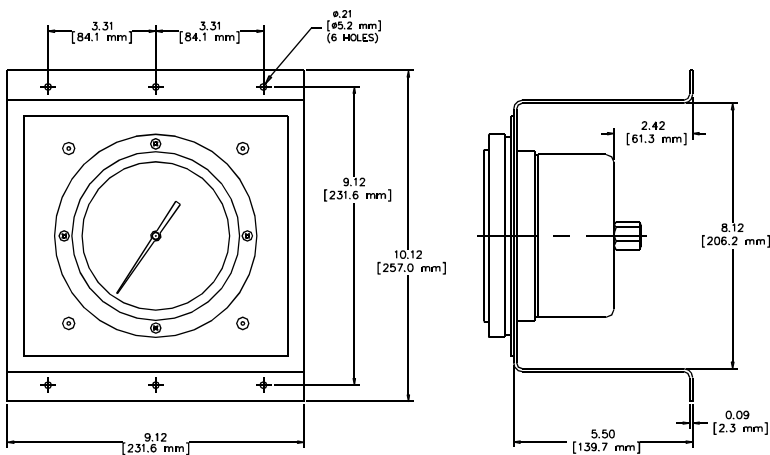

TROUBLE SHOOTING

1. **Gauge does not indicate differential**
 - A. Check for proper hook up, high to "HIGH" and low to "LOW"
 - B. Make certain block valves are open and, if using a 3-valve manifold, that the equalizer (balance) valve is closed.
 - C. If A & B check out correctly, loosen or disconnect the high pressure line to determine if there is pressure to the instrument.
 - D. If there is pressure to the instrument, check to determine that there is differential across the unit being monitored. If so, contact the factory for assistance and/or an "RGA" (return goods authorization) number to return the instrument for repair or replacement

2. **Indicating pointer off zero. (With block valves closed, or no system differential)**

- A. Tap gauge **lightly**.
- B. Make certain block valves are closed and equalizer valve is open.
- C. If A & B do not correct the "off zero" condition, remove the bezel and lens assembly by removing the (4) bezel screws. Slightly loosen the "phillips head" screw, located in a slot in the dial, in the lower left dial area at about "7:30". Rotate the dial until "zero" is under the pointer by use of any pointed object inserted in one of the small notches in the top and bottom of the dial. Retighten the "phillips head" screw and reinstall the bezel and lens assembly.

Recalibration and/or Repair

1. If recalibration or repair is required, secure an "RGA" (returned goods authorization) number from Mid- West Instrument and return instrument to the factory.
2. If (1) is not practical we recommend you discuss your problem with one of our customer service representatives and request a "technical service" manual. Please have both the model and serial numbers available before calling.