

Model 220 Transmitter Electrical: Installation and Operating Instructions Hazardous Locations:

ELECTRICAL

Upon receipt of your order, please review the ratings plate to verify that the model number and the electrical ratings match the product that you ordered. The transmitter is CE marked in accordance with the ATEX directive. **Please read the Cautions listed on the Rating Plate as they are different for each Electrical Configuration. The markings and warnings identified on each plate are applicable only to their respective Hazardous Locations classifications. I.e; if the assembly is installed in an ATEX classified location, then the ATEX ratings plate shall govern.**

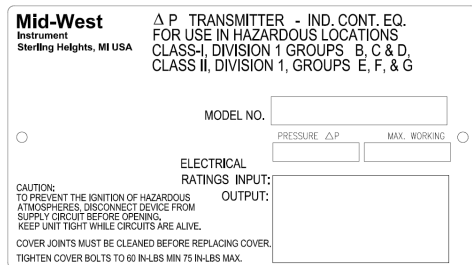

FIGURE 1

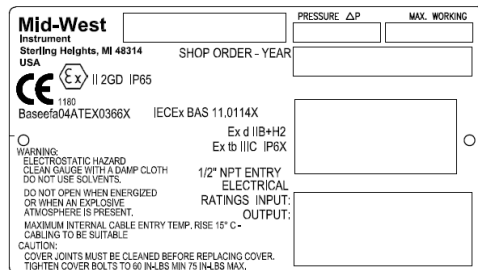

FIGURE 2

WARNING: This product should be installed by personnel trained in installation of equipment in Hazardous Locations and meet the representative country's National Electrical Code.

WARNING: Electrostatic Hazard: Clean all exposed plastic surfaces with a damp cloth. Do not use solvents

WARNING: To meet Hazardous Location's Requirements, torque the cover bolts to the specified values on the Ratings plate.

WARNING: The maximum gap permitted between the body and cover is less than the maximum permitted in the standard. Therefore it is the responsibility of the user of this equipment to ensure the maximum gap between the body and the cover is not greater than 0.038mm (0.0015").

Caution: Do not scratch, nick, or dent mating surfaces of the gauge body and the cover during maintenance. The integrity of the flame-proof enclosure is dependent upon this metal to metal seal.



If cover bolts are lost or damaged, they SHALL be purchased from Mid-West Instrument for replacement. The bolts are non-standard and have been designed specifically for the referenced Hazardous Locations in this document.

Clean Metal joint area with non-abrasive cloth after any maintenance activity that requires the cover to be removed. A small amount of non-hardening grease may be applied in the joint area.

In dust environments some minor surface layering may occur. Routine cleaning shall be performed for removal of the dust layer.

NOTE: This instrument will have a small amount of leakage from Hi to Lo. Due to precision sizing of the piston and the body bore, leakage will not exceed 15 SCFH at 100 PSID at ambient conditions.

DIVISION 1 LOCATIONS:

The Model 220 Transmitter is intended for use in Class 1, Division 1, Groups B, C & D; Class 2, Division 1, Groups E, F, & G Hazardous Locations. This enclosure does not have a NEMA 4X rating.

This configuration has a T6 Temperature classification

ATEX IECEx CERTIFIED 
(Group II Category 2 Gas & Dust Atmospheres):

The Transmitter is ATEX & IECEx Certified for Gas & Dust Atmospheres as:

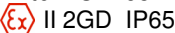
Ex d IIB + H₂ T6 (-30°C ≤ Ta ≤ 65°C)Gb
Ex tb IIIC IP65 T85°C (-30°C ≤ Ta ≤ 65°C)Gd

The transmitter assembly as a component has passed numerous European EMC standards (ie; Compliance to IEC EN61326). Contact the factory if additional low pass filtering is necessary.

Installation



Tools Required: 8mm deep metric socket.
Torque wrench
Adjustable or 1.125" wrench (process connections)

CAUTION: Do not exceed the maximum rated working pressure stated on the ratings plate.

CAUTION: Always use a wrench (1.125") on the switch's process connections to keep them in place while loosening and tightening customer supplied process fittings.

WARNING: Verify media compatibility with all wetted parts. Range spring is manufactured from 316SS. Media incompatibility with the spring or the body of the gauge can result in an ignition hazard due to corrosion.

WARNING: Use pressure limiting devices to limit pressure spikes below the proof pressure of the gauge / switch.

Locate unit where temperatures will be within the limits of the device hazardous' locations ratings.

On liquid service the instrument should be mounted **below** the process connections to facilitate self bleeding. On gas service it should be located **above** the process connections to promote self-draining. If the process contains particulates, a "pigtail" loop or drop leg (manometer "U-tube" configuration) in the tubing will minimize the possibility of it migrating into the instrument. An optional pipe mounting kit is available for mounting the gauge to a 2" vertical or horizontal pipe.

A provision for special mounting is provided on the back of the gauge.

Connect process piping or tubing to the pressure ports stamped High and Low on the gauge body. Connections are either 1/4" FNPT or 1/2" FNPT dependent upon the option selected when the order was placed.

Reverse pressure will not damage the instrument.

CAUTION: Use cable suitable for the specified temperature class. Maximum internal cable entry temperature rise is 15 °C – Cabling to be suitable.



WARNING: Electrical connection shall be made with a cable entry or stopping box certified for use for the desired hazardous location, certified for condition of use, and correctly installed. The cable entry device and any thread adaptor shall be suitable for the equipment, the cable, and the conditions of use, and shall be certified as equipment (Not an EC component) under the EC Type Examination Certificate to directive 94/9/EC.

WARNING: When used in an explosive dust atmosphere, the cable entry device and thread adaptor shall maintain the ingress protection of the enclosure.

WARNING: During maintenance do not disconnect from external earth conductor until all power generation systems have been turned off.

WARNING: In Hazardous Locations remove power from the unit before removing the cover.

Remove the cover by using an 8mm hex driver to loosen the bolts from the underside of the gauge body. (see previous cautions and warnings). The bolts are captive in the body of the gauge. A deep metric socket is recommended in order to clear an interference near the bezel of the gauge. (0.48 diameter min 1" long).

Connections to the terminal strip are identified in the following sections. The terminal strip is compatible for wire ranges from 12-22 AWG (3.3 - .32 mm²). Optionally, each connection can be field wired with multiple wires connected to one contact. You may connect two (2) 22 – 16 AWG (0.33 -1.3 mm²) wires into one connection. Recommended screw torque is 6 in. lbs. (0.113 newton-meter) to tighten the terminal strip screw.

Each Assembly is provided with strain relief clamps. Use these clamps to provide strain relief when field wiring the instrument.

For the non-gasketed assembly, clean both mating metal surfaces prior to re-assembly (see previous cautions and warnings). A small application of a suitable, non-hardening grease may be applied to the mating metal surfaces. Replace cover making sure there are no wires pinched between the cover and the gauge body. Re-tighten the screws within the range of 60 to 75 in-lbs.

General Information:

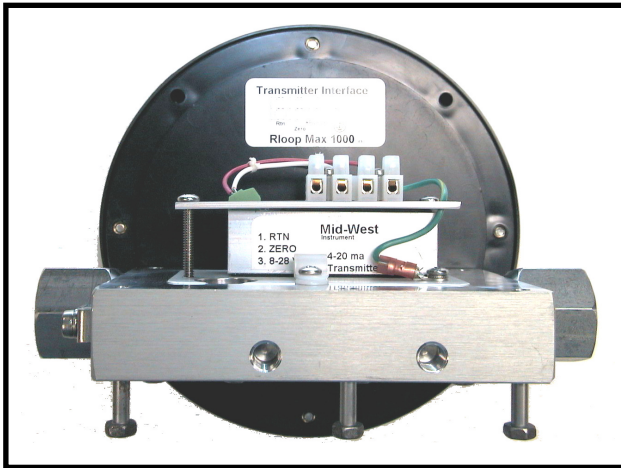

FIGURE 3

The Model 220 indicating / non-indicating differential pressure transmitter is a 2 wire loop powered microprocessor based 4-20 ma transmitter. The magnetic angle sensor & electronics senses the angle (relative to the transmitter sensor) of the magnet which moves linearly in the bore. Each transmitter is individually calibrated to the gauge using an 11 point calibration linearization technique. This method results in a <2% full scale accuracy for the upper 80% of the range.

In addition an external zero pin is available for simple zeroing after installation.

Caution:

Do not attempt to reposition the transmitter assembly within the enclosure. This voids the warranty and will “knock” the unit out of calibration.

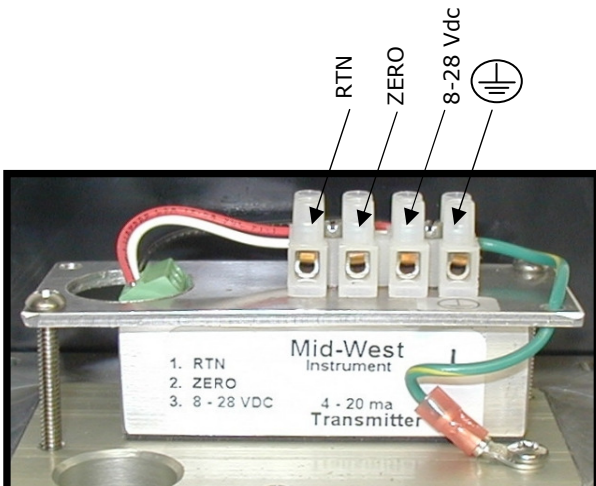

FIGURE 4

The explosion-proof enclosure comes standard with a ½” FNPT conduit interface. Internal to the enclosure is a 4 position terminal strip. The terminal strip accepts wire sizes 22 AWG – 12 AWG. Connections are defined in Figures 4 & 5.

Route field wiring through the provided strain relief clamp. Connect loop power between the connections labeled 8-28 Vdc and RTN. Connect the protective conductor wire to the terminal with the Ⓧ symbol. A remote zero is also available. To zero the transmitter, connect “Zero” to “RTN” for a minimum of 2 seconds. For normal operation, the zero connection is left unconnected.

The maximum loop resistance is 1000 ohms (@ 28Vdc Input). Use the following formula to determine the maximum loop resistance at other input voltages:

$$((V_s - 8) / 20) * 1000$$

FIGURE 5 Interface Schematic

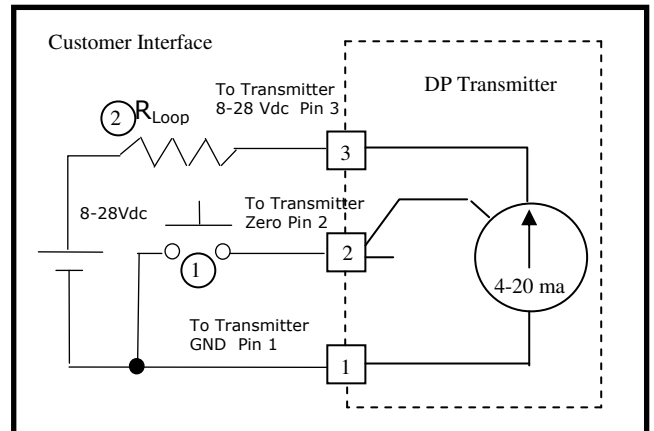

- ① Optional remote zero (customer supplied)
- ② Loop Resistor can be located in the ground leg

Occasionally the transmitter may require a “re-zero”. In Hazardous locations it is recommended that this be performed remotely (ie; from a non-hazardous area) or move the assembly to a non-hazardous location.

TROUBLE SHOOTING

1. Gauge does not indicate differential.

- A. Check for proper hook up, high to "hi" and low to "lo".
- B. Make certain block valves are open and, if using a 3-valve manifold, that the equalizer (balance) valve is closed.
- C. If A & B check out correctly, loosen or disconnect the high pressure line to determine if there is pressure to the instrument.
- D. If there is pressure to the instrument, check to determine that there is differential across the unit being monitored. If so, contact the factory for assistance and/or an "RGA" (return goods authorization) number to return the instrument for repair or replacement.

2. Transmitter doesn't function

- A. Make sure you have supplied power (proper voltage) to the unit.
- B. Check that you are wiring to the correct Interface terminals.
- C. Check the transmitter interfaces to the terminal board for loose connections.
- D. Make sure that the loop resistance does not exceed the specified rating.

3. Gauge accuracy and set point problems:

- A. Verify gauge is not in an electromagnetic / magnetic environment. i.e.; close proximity to high current power lines.
- B. All others, contact the factory for assistance

TRANSMITTER SPECIFICATIONS

Transmitter Specifications:				Comments:	
Differential Pressure Range	0-5 PSID to 0 -100 PSID				
Leakage	15SCFH @100 PSID Max Hi to Lo			Not recommended for use with Lo port left open to atmosphere.	
Pressure (Ratings)					
Max Working	3000 PSIG				
Gauge Accuracy	2%			ASME B40.100 GRADE B	
Operating Temperature (Max.)	-20° F - 150° F				
ELECTRICAL:					
		Min	Typ	Max	
Transmitter Accuracy (FSR)				2%	Upper 80% of Full Scale Range
Supply Voltage (3) (Vdc)		8		28	Pin 3 Reverse Polarity Protected
Output Current (ma)					
Zero Floating (2)	4.0 – 20.1 ma		4.0 – 21.0	4.0 – 22.0	Pin 2
Zeroed (1 connected to 2)			8		
Voltage (Pin 2 to 1)	4.8			6.3	
Zero Time (seconds)	2				
Max Loop Resistance (ohms)				1000	
Max Loop Resistance Formula	((Vs – 8) / 20) * 1000)				
INTERFACE:					
Electrical:					
Connections:	4 Position Terminal Strip; ½" NPT Conduit 1= Rtn, 2= Zero, 3 = 8-28 Vdc In 4= Chassis			22 Awg – 12Awg Wire	
Environmental Rating:	Explosion-proof Enclosure rated Class I, Div I, Groups B,C,D; Class II, Div I, Groups E, F, & G **				
Certifications:	Ex d IIB + H ₂ T6 (-30°C ≤ Ta ≤ 65°C)Gb Ex tb IIIC IP65 T85°C (-30°C ≤ Ta ≤ 65°C)Gd ATEX and IECEx				

MOUNTING INFORMATION & DIMENSIONAL DATA

MODEL 220 4 1/2" PLASTIC DIAL ASSY.

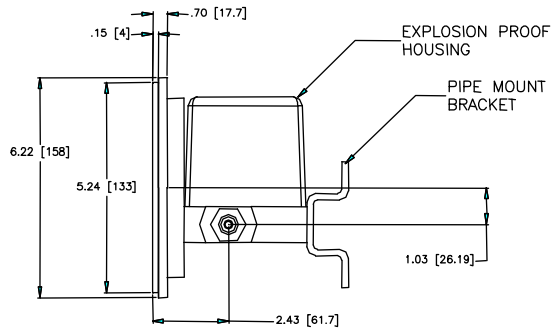
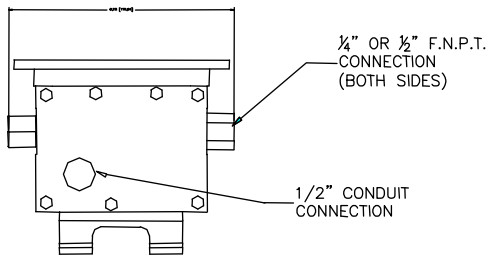
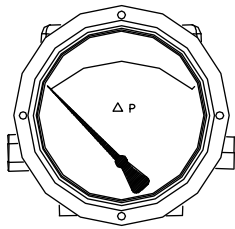

NOTES:

1. Drawings show standard gauge nominal dimensions. (not to scale)
2. Dimensions shown in parentheses are in millimeters.
3. Mounting dimensions for 4 1/2" aluminum dial assy.—contact factory.

PROOF PRESSURE: 12,000 PSI

WORKING PRESSURE: 3000 PSI

TEMPERATURE LIMITS: -20° F TO + 150° F - These limits are based on the entire instrument being saturated to these temperatures. System (process) temperatures may exceed these limitations with proper installation. Contact our customer service representative for details.

STANDARDS: The Model 220 Series differential pressure gauges either conform to and/or are designed to the requirements of the following standards:

ASME B1.20.1
 ASME B40.100
 CSA-C22.2 No. 14, 25, and 30
 UL Std. No. 50, 508, 698, and 1203

NEMA Std. No. 250
 SAE J514
 EN60079-0, EN60079-1 and EN13463-1
 IEC 60079-31

Warning: The suitability of the application and installation of this differential pressure switch is the responsibility of the end user. The applicable certifications, listings apply to the differential pressure switch only.

Warranty: Gauge & Mechanical: 5 Years; Electrical: 1Year

**Mid-West[®]
 Instrument**

6500 Dobry Dr. Sterling Heights, MI 48314
 (586)254-6500 FAX (586)254-6509
 E-Mail: sales@midwestinstrument.com
 Web Page: www.midwestinstrument.com